



EDGE LEARNING APPLICATIONS GUIDE

AI for Everyone and Every Industry

EDGE LEARNING

AI FOR EVERYONE AND EVERY INDUSTRY

From the products we use everyday at home and in our jobs, as well as the distribution systems used to get them from the manufacturer to our homes and businesses, the consumer economy has started to tap into the human-like processing power of artificial intelligence (AI). Within the AI realm is edge learning. This easy-to-use and simple-to-setup automation technology is now migrating into advanced manufacturing and logistics practices for quality inspection and task automation.

Edge learning is a versatile technology that can be trained to identify, detect, and classify product defects, components, labels, and other features, lending itself to endless industrial applications. Leveraging pre-trained AI algorithms, edge learning expedites the system training process without compromising performance. Edge learning technology simplifies automated defect detection, assembly verification, classification, character reading, and similar applications that would be too complex for traditional machine vision or too costly for manual labor.

EDGE LEARNING APPLICATIONS BY INDUSTRY

Automotive	3
Electronics	4
Life Sciences	5
Logistics	6
Packaging	7
Cognex AI Solutions	8
Cognex Global Services	9

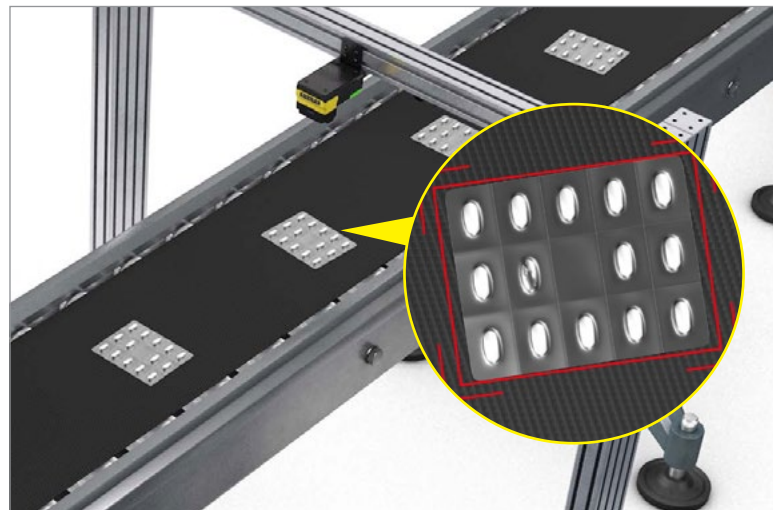
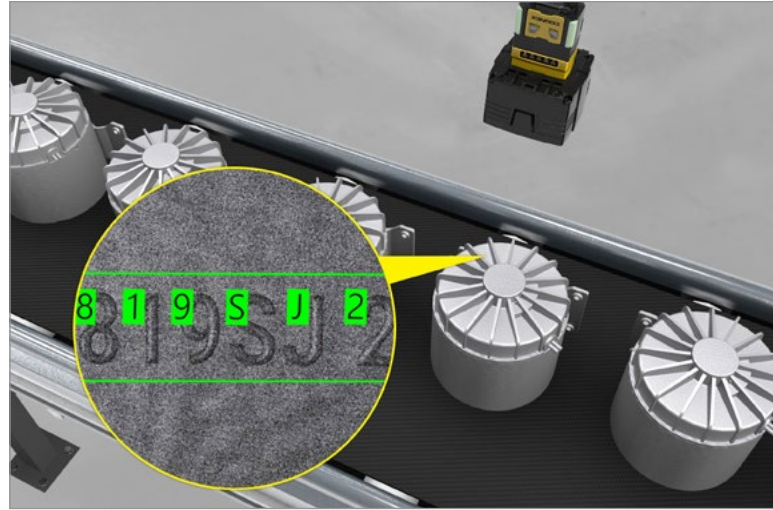

AUTOMOTIVE

Automakers and their suppliers are competing on a global scale, driving manufacturers to reduce costs, implement advanced features, and safeguard their products. As traditional automakers transition into the electric vehicle market, more companies are competing for a limited quantity of rare, expensive metals and personnel. Edge learning technology alleviates these burdens, reducing costs and optimizing workforce utilization by automating complex tasks such as inspection, part classification, as well as reading direct part markings (DPM) and label-based codes.

Optical character recognition

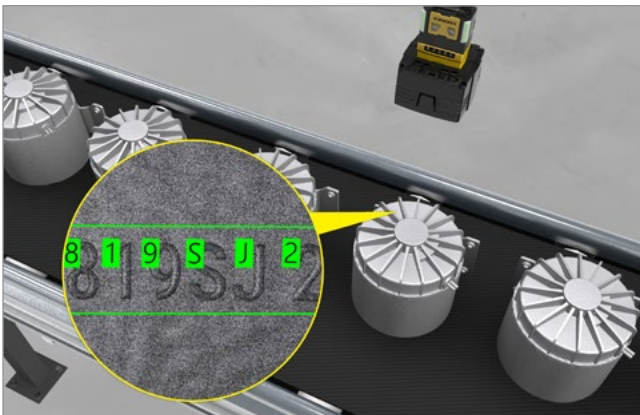

Vision systems with edge learning instantly read codes and direct part markings, even in low-contrast conditions and when the code is damaged.

Connector insertion check

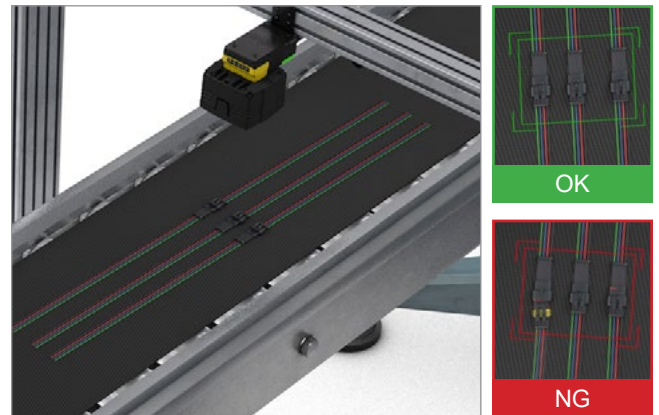

Vision systems embedded with edge learning can verify if connectors have been properly inserted in wiring harnesses.

Textured metal sheet

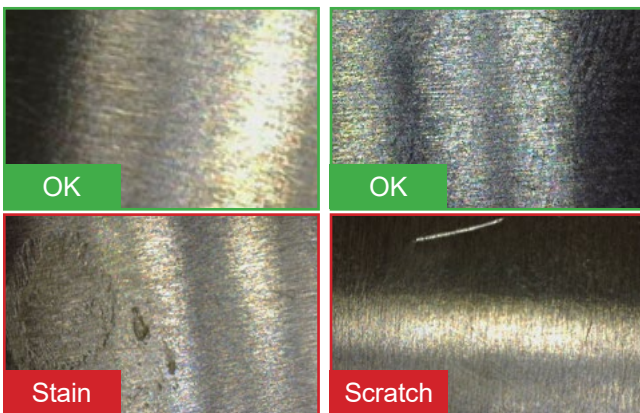

Leverage edge learning technology and machine vision to detect and classify imperfections, as well as differentiate between flaws and acceptable anomalies.

Inspection and presence/absence

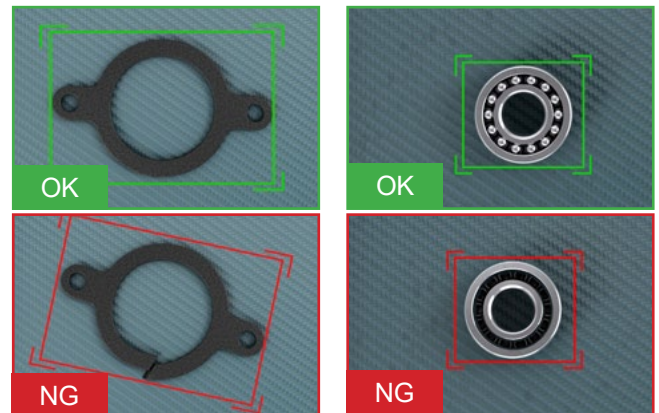

Confirm the presence or absence of specific components with edge learning tools.

ELECTRONICS

Edge learning technology is ideal for use in automated inspection processes by electronics manufacturers and assembly facilities. Cognex edge learning solutions are easy to use and quick to deploy for high-volume component quality checks or assembly verification.

PCB component assembly verification

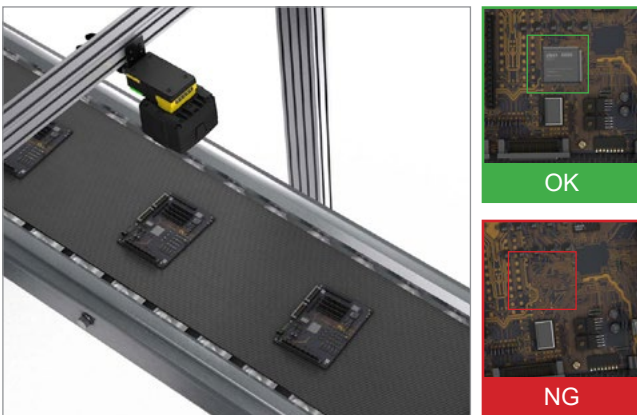

Vision systems embedded with edge learning verify correct assembly of PCBs.

Resistor quality check

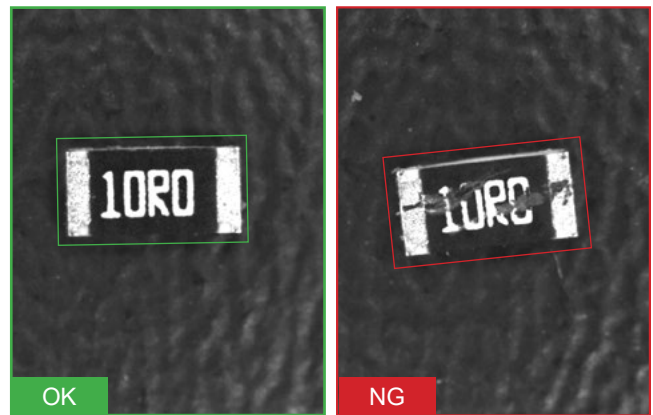

Inspect resistors and classify them as NG (damaged or scratched) or OK with edge learning tools.

LED quality check

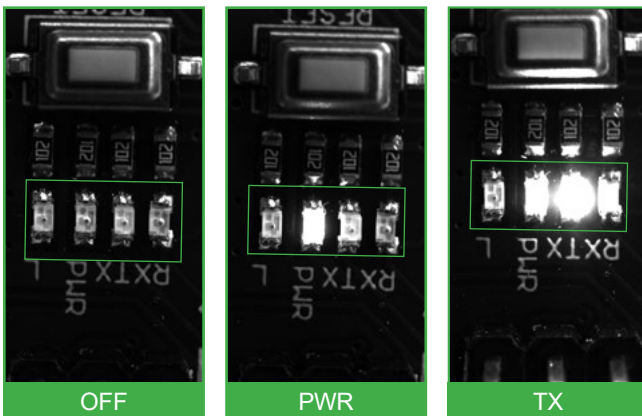

Edge learning technology verifies proper operation of LEDs on PCBs by classifying the different statuses as either OFF, ON, or PWR.

Connector prong quality check

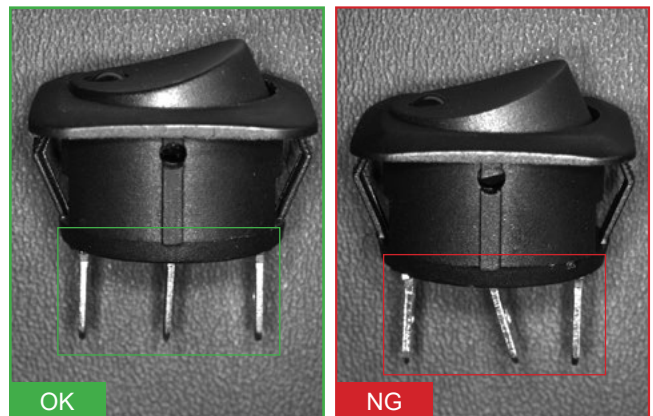

Check the quality of connector prongs on electronic components with edge learning tools.

LIFE SCIENCES

Edge learning can automate complex, inefficient tasks in lab diagnostic environments to produce consistent results. Physicians, researchers, and other edge learning novices can train applications and generate valuable data within minutes.

Pathology sample identification



Vision systems with edge learning read and decipher characters on flexible, shiny surfaces.

Test tube classification

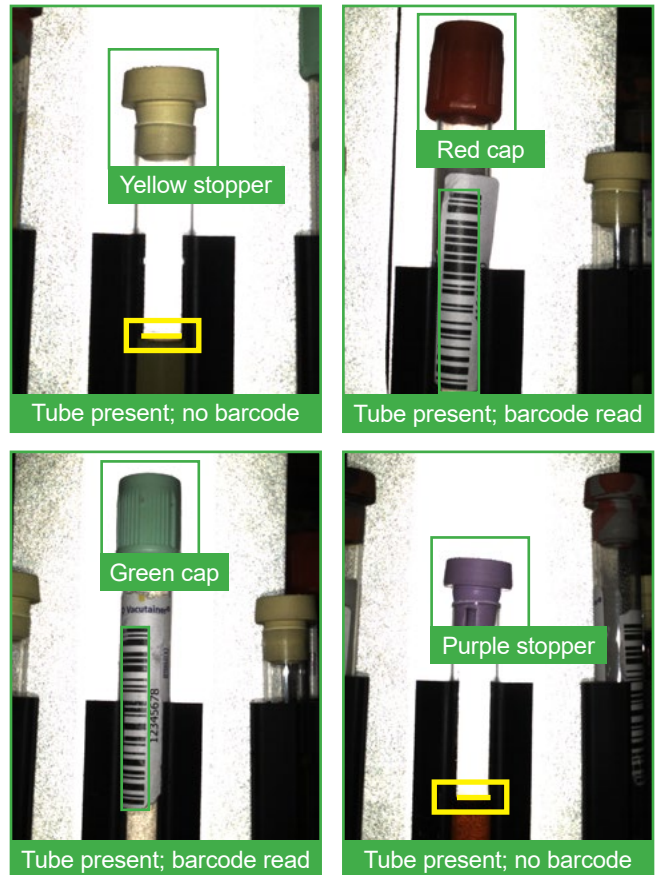

Automatically classify test tubes and cap type along with determining the liquid level.

LOGISTICS

Edge learning technology solves challenging vision applications, including difficult item detection and object sortation. With simple example-based training and AI algorithms, Cognex edge learning solutions enable logistics facilities to elevate the efficiency of sortation processes and handle a wide variation of item and packaging types.

Presence/absence detection

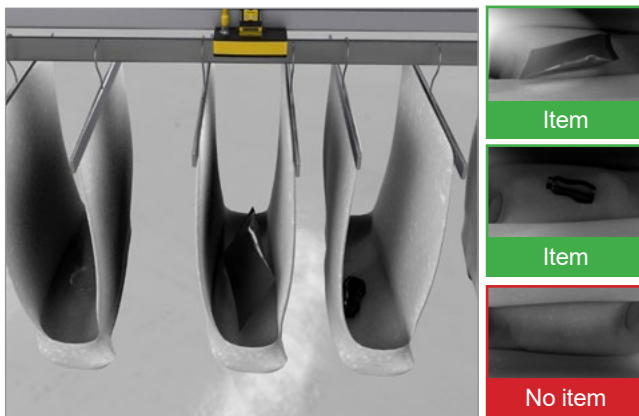

Cognex's vision systems embedded with edge learning detect the presence or absence of challenging items on varying background on totes or trays.

Sortation

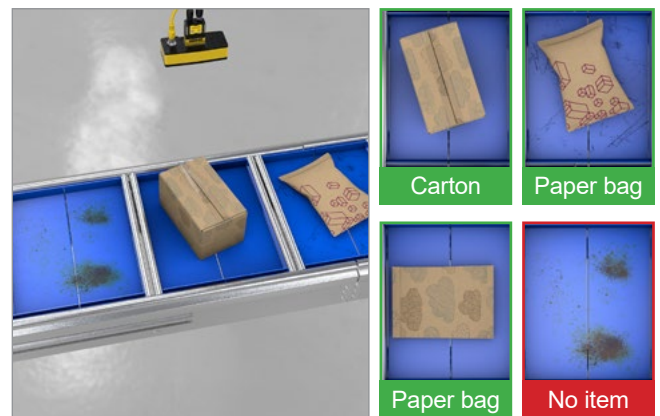

Edge learning can be trained on any packaging type to ensure items are routed correctly.

Process issue detection

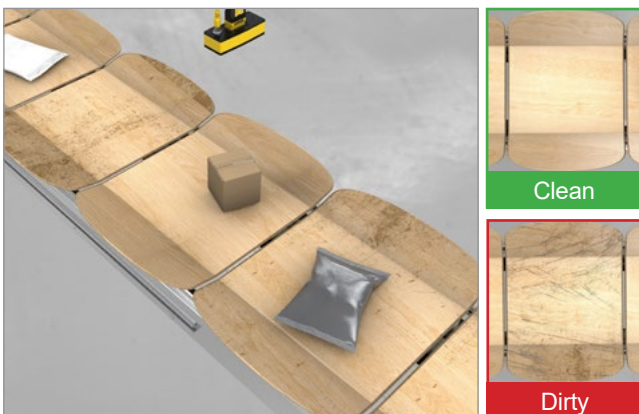

Vision systems with edge learning detect the hygiene of trays, as well as items stuck within cross-belt sorters or conveyors. These insights help prevent equipment damage or delays in processing.

PACKAGING

Edge learning technology simplifies automated inspections for packaging manufacturers. With unmatched ease of use, Cognex edge learning solutions are ideal for verifying proper assembly, detecting missing product from packaging, as well as classifying a variety of defects to assist with process optimization.

Blister pack check

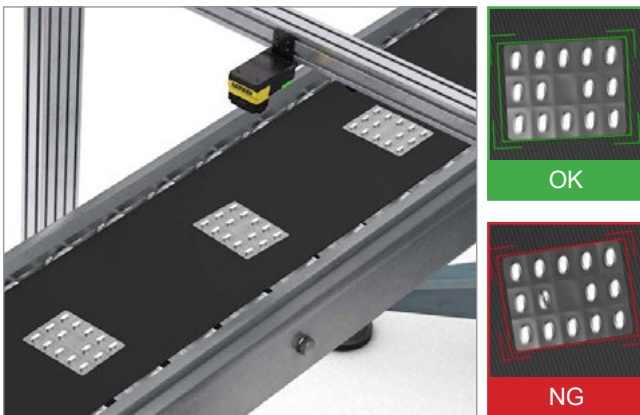

Machine vision systems use edge learning to classify how pills are packaged in blister packs, even under reflective packaging.

Classification and sortation by size and color

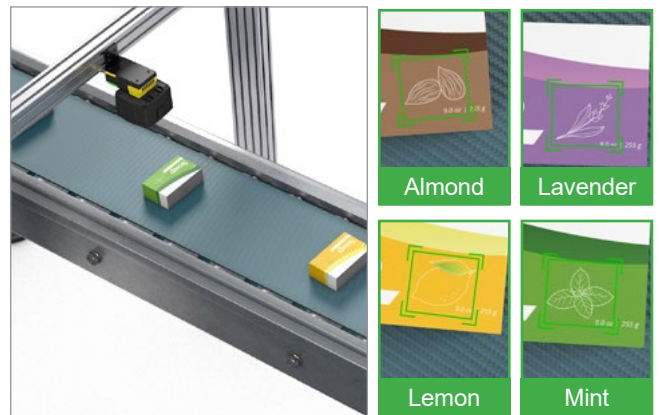

Classify and separate products based on size, color, and visual characteristics using edge learning tools.

Missing product detection



Machine vision combined with edge learning technology inspects packages for missing items.

Medical kit assembly verification

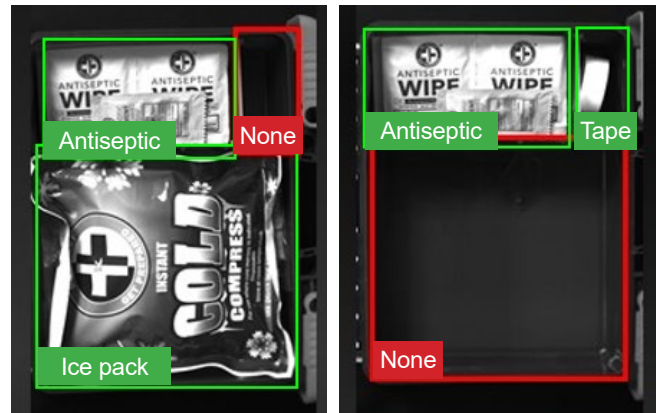

Edge learning classification tools identify if parts are present in packaged first aid kits.

COGNEX AI

Cognex AI learns to spot patterns and anomalies from example images. It solves tasks that are too complicated and time-consuming to program with rule-based algorithms, while providing a consistency and speed that aren't possible with manual inspection.



Edge learning: Designed for ease of use

Edge learning is a subset of AI in which processing takes place on-device, or "at the edge," using a pre-trained set of algorithms. The technology is simple to setup, requiring smaller image sets and shorter training and validation periods than traditional deep learning-based solutions.

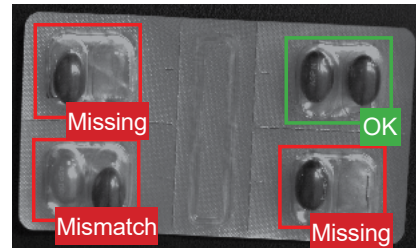

Deep learning: Designed for complex applications

Capable of processing large, detailed image sets, deep learning is designed to automate complex or highly customized applications. The technology enables users to analyze vast image sets quickly and efficiently, while differentiating between acceptable and unacceptable anomalies, to deliver accurate results.

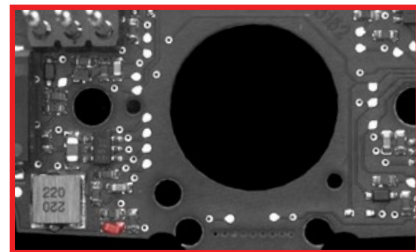
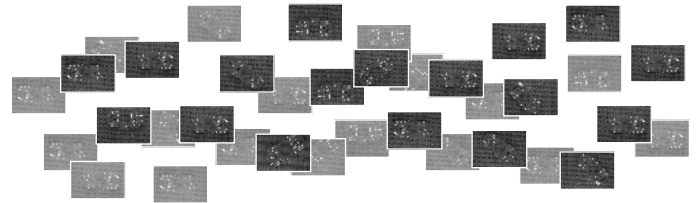

Cognex AI resources



Watch *Machine, Deep, or Edge Learning: What's the Difference?*

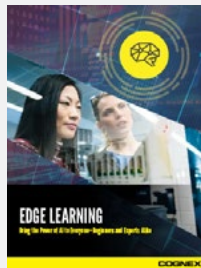

Read *Edge Learning: The Power of AI for Everyone*

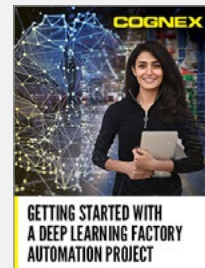

Read *Getting Started with a Deep Learning Factory Automation Project*

COGNEX GLOBAL SERVICES

Technical Support ▪ Product Training ▪ Self-Service Portal ▪ Lifecycle Management

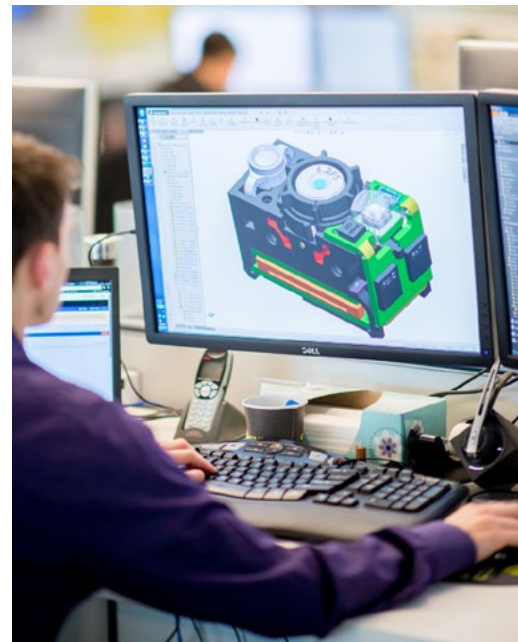

Cognex serves an international customer base from offices located throughout the Americas, Europe, and Asia and through a global network of highly-trained partners, system integrators, and distributors.

From development to deployment, Cognex is there to get your vision systems up and running as fast as possible. Whether you're considering machine vision for the first time or are already an expert user, Cognex global services provide the expertise to help your organization succeed.

cognex.com/support/cognex-services



Offices in **20+** countries

500+ Global partners in 30 countries

The Global Leader

in Machine Vision and Barcode Reading

For over 40 years, Cognex has helped the world's most innovative companies make their manufacturing and distribution faster, smarter, and more efficient.

Cognex machine vision solutions combine hardware and software to capture and analyze visual information. The company's wide range of solutions automates manufacturing and distribution tasks for customers worldwide, improving efficiency and quality in applications like inspecting, identifying, locating, and measuring components, products, and packaging. Cognex products incorporate advanced technologies including artificial intelligence to simplify implementation, increase accuracy, and deliver a faster ROI.



>40 years in business

\$830M+ 2023 revenue

>60% revenue from EU & Asia

25K+ global customers

400+ channel partners

500+ global customer support resources

17% of revenue into R&D

>1,100 technology patents

>8 years developing AI for industrial machine vision

BUILD YOUR VISION

Vision Systems

Automate inspection tasks, from defect detection to assembly verification and text reading, with easy to deploy vision systems.

www.cognex.com/machine-vision



Barcode Readers

Track and trace, from the floor to dock door, with powerful readers and verifiers designed to handle any code type.

www.cognex.com/barcodereaders



Industry Solutions

Solve applications across a wide range of industries with flexible and reliable machine vision and barcode reading solutions.

www.cognex.com/solutions

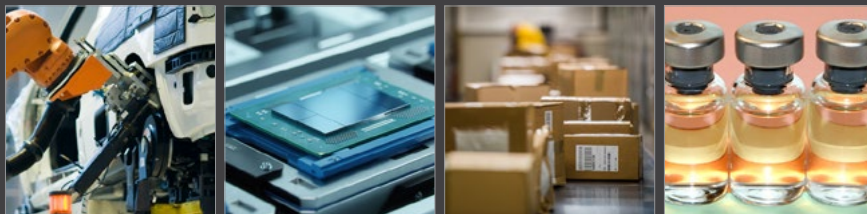

COGNEX

Companies around the world rely on Cognex vision and barcode reading solutions to optimize quality, drive down costs and control traceability.

Corporate Headquarters One Vision Drive Natick, MA 01760 USA

Regional Sales Offices

Americas

North America +1 844 999 2469
Brazil +55 11 4210 3919
Mexico +800 733 4116

Europe

Austria +43 800 28 16 32
Belgium +32 289 370 75
Czechia +420 800 023 519
France +33 1 76 54 93 18
Germany +49 721 958 8052
Hungary +36 800 80291

Ireland +353 21 421 7500
Italy +39 02 3057 8196
Netherlands +31 207 941 398
Poland +48 717 121 086
Romania +40 741 041 272
Spain +34 93 299 28 14
Sweden +46 21 14 55 88
Switzerland +41 445 788 877
Turkey +90 216 900 1696
United Kingdom +44 121 29 65 163

Asia-Pacific

Australia +61 2 7202 6910
China +86 21 5875 1133

India +91 7305 040397
Indonesia +62 21 3076 1792
Japan +81 3 5977 5400
Korea +82 2 539 9047
Malaysia +6019 916 5532
New Zealand +64 9 802 0555
Philippines +63 2 8539 3990
Singapore +65 3158 3322
Taiwan +886 02 7703 2848
Thailand +66 6 3230 9998
Vietnam +84 98 2405167

© Copyright 2023, Cognex Corporation.
All information in this document is subject to change without notice. All Rights Reserved. Cognex and Build Your Vision are registered trademarks of Cognex Corporation. All other trademarks are property of their respective owners.
Lit. No. ELAG-EN-04-2023

www.cognex.com